

DOUBLE SYSTEM ME DUAL PH E REDOX

DESCRIPTION

- Double system with built in PH/ REDOX and Temperature C° controller
- Flow rate in %
- 3 different operating mode: constant, ON / OFF, proportional
- Menu available in 4 languages: Italian, English, French, Spanish
- Start up delay
- Timed overdose alarm (TAL System Protection)
- Alarm relay (free contact)
- Default parameter restore option
- PH Stability mode
- STAND BY modality
- Over / under range signal
- Backlit LCD display
- PP reinforced box IP 65
- 230 V 50-60 Hz standard power supply

OPTIONAL

- Level probe input
- Flow sensor input
- ON / OFF switch
- PP pump heads



SPECIFICATIONS

Standard	Max l/h	Pressure		Max cc / imp	Stroke	Solenoid	Pump Head	Power [Watt]	Pulses	Weight	
		Bar	PSI							kg.	Lbs
REDOX pump	10	02	29,4	1,11	1,3	Ø 80	PVDF	60	150	8	15,3
PH pump	05	10	145	0,55	1,1	Ø 80	PVDF	60	150		

**DOUBLE SYSTEM
ME DUAL PH E REDOX**

DIMENSIONS (MM)

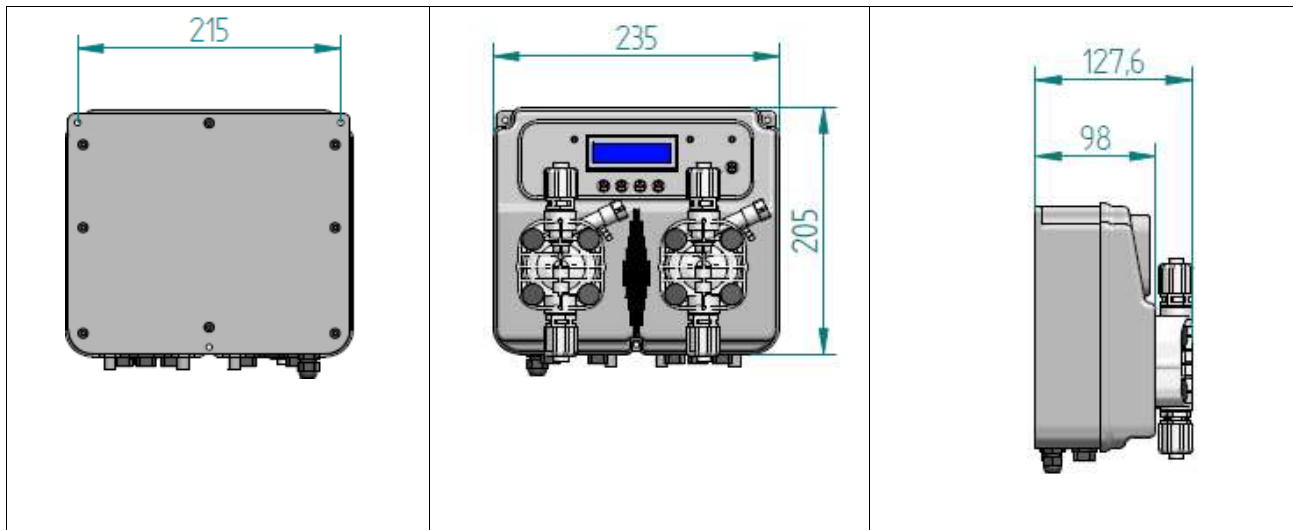



ME DUAL PH REDOX



DOUBLE SYSTEM ME DUAL PH E REDOX

ACCESSORIES KIT

Injection valve
PVDF SP VITON

Foot filter
PVDF SP VT

Delivery tube
2mt
PE 4x6

Suction tube 2mt
PVC 4x6

Bleed tube
1,5mt PVC 4x6

STANDARD KIT



Dosita S.r.l.

www.dosita.com - info@dosita.com

e-shop: www.trattamento-acque.net - info@trattamento-acque.net